

EKS *Light* *Light FSA*



More than safety.



EUCHNER

The Electronic-Key-System EKS

This system is already established in many applications involving electronic access management on PCs and control systems. The user employs the Electronic-Key with RFID transponder to identify himself to the Electronic-Key adapter. Thanks to the special design of the Electronic-Key adapters, the Electronic-Key can be placed on the installation during operation.

The EKS is widespread amongst automotive manufacturers and suppliers. Further applications include uses in the process-oriented industry, e.g. in the production of food, pharmaceutical or chemical products. Protecting access to critical processes is a central topic in the typical applications.

The existing EKS family is being expanded by another series with the EKS *Light*. With EKS *Light*, EUCHNER is now opening up the use of EKS technology for small and decentralized applications as well.

Due to the non-contact transfer of data, it was possible to design the Electronic-Key adapters from the access side with a high degree of protection. Thanks to its robust design, the EKS is appreciated as one of the few truly industry-compatible systems.

The EKS is well-known in the compact version

Here, the Electronic-Key adapter and the electronics with the interface form a unit. The Electronic-Key latches into the Electronic-Key adapter and is retained there. The compact EKS *Light* Electronic-Key adapter can be identified by the black front cover.

Light



Even more options with the modular EKS

Here, the Electronic-Key adapter is mounted spatially separate from the electronics. The modular Electronic-Key adapter allows the Electronic-Key to be recognized at the front upon approach, and the Electronic-Key can also be placed by hanging it if necessary. With the modular design, the electronics is accommodated in a separate interface adapter mounted in the control cabinet or on a DIN rail, for example.

The special features and advantages of the modular Electronic-Key adapter:

- Compact design for installations where there is little space
- Installation in standard mounting hole Ø 22,5 mm
- Closed design, rounded contours for hygienic areas
- Plastic with high resistance to media

The shallow installation depth permits installation in flat control panels as well. Since this version fits in a Ø 22.5 mm hole, it is often the simplest solution for retrofitting in particular.

The Electronic-Key adapter was designed for applications in hygienically sensitive areas, with simple cleaning being of primary importance here. The high-molecular-weight plastic also permits use in the food industry.

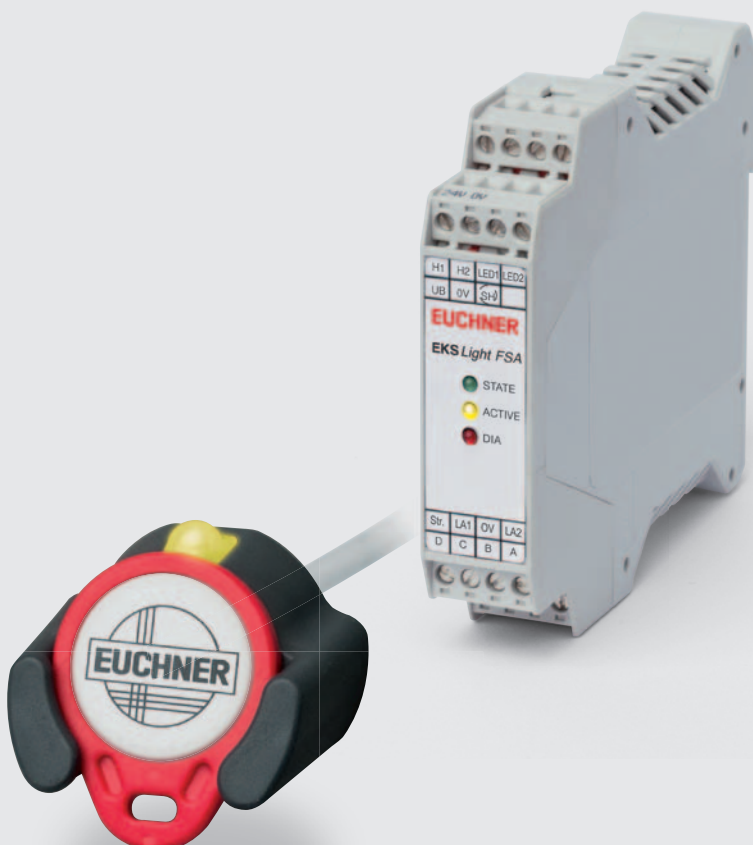

Access the easy way...

A simple connection concept as well as rapid and therefore economical integration into the control environment were at the forefront in the development of EKS *Light*. Compatibility with the existing EKS through the use of the same Electronic-Keys was also taken into account.

- Electronic access control
- Simple connection
- Simple communication, 4-bit output
- Very flexible use

As previously with EKS, the *Light* version also permits controlled access to individual machines, entire installations or other facilities. The only difference is that with EKS *Light*, the device directly identifies a user by his Electronic-Key. A control system is not necessary for this check. If an authorized user was detected, an access level is output with which the user receives a certain authorization. The derivation of access rights onto machine functions is carried out through the programming of the control by the system integrator.

And this is how it works

The EKS *Light* Electronic-Key adapter is a read-only system with integrated evaluation electronics and interface.

After the key is inserted, the key's data are evaluated within the device as the first step, which permits automatic user recognition without the aid of the control system.

Once the internal check of the data integrity is complete, an access level is issued. The access level is output via a 4-bit parallel interface. The parallel interface offers the advantage of transparent depiction of the data and therefore simple connection directly to the inputs of a control system or a switching device.

An EKS operating state, an access level, an access code, a checksum (CRC) and a serial number are stored on the Electronic-Key. When a key is inserted, the data range relevant for the respective operating state is automatically read from the key into the device, temporarily stored there and evaluated. If an authorized user is recognized via a valid Electronic-Key, the outputs on the Electronic-Key adapter are set to High in accordance with the stored access level values. All outputs are reset to Low when the Electronic-Key is withdrawn.

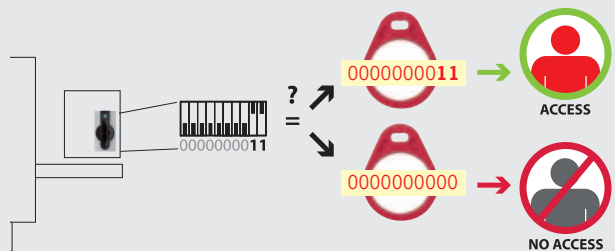

The Electronic-Key adapter and Electronic-Key are separately parameterized, with values which have to match. Parameter assignment to the Electronic-Key adapter is performed very simply through DIP switches.

4-Bit parallel interface for output of the access level

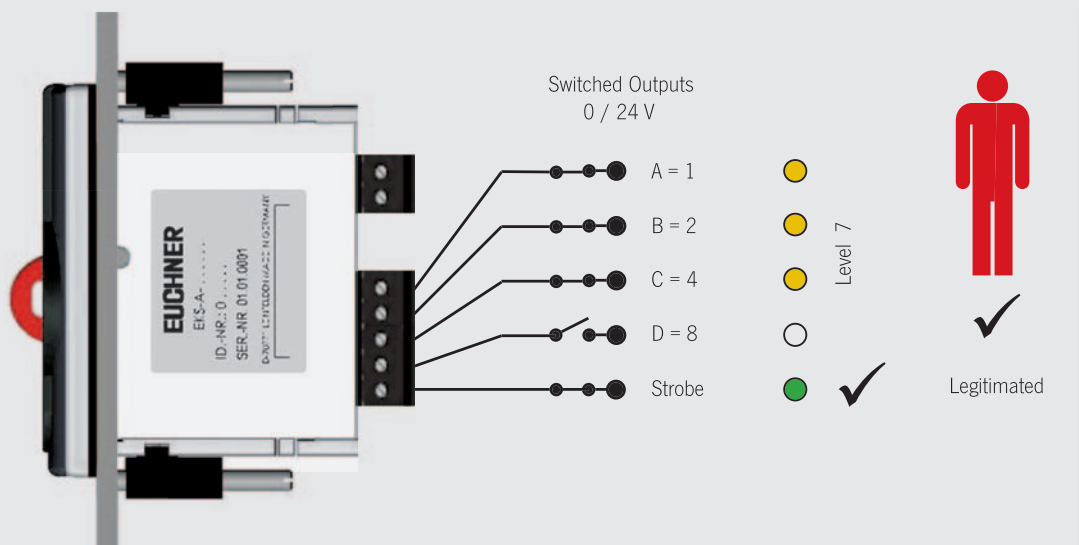

Flexibility through various operating states

The application options for EKS *Light* are diverse, and the flexible concept with its different operating states provides flexibility for planning.

The operating state determines the function of the system, which comprises the Electronic-Key adapter and Electronic-Key. The operating state defines the scheme according to which automatic Electronic-Key recognition functions and how an access level is issued.

What operating states are available?

Depending on the applications, various operating states can be selected. Two different operating states are available in the first step.

- Operating state 0
Access is granted when the access codes on the Electronic-Key and DIP switch are an exact match. 1024 codes are possible in this operating state.
- Operating state 1
Access is granted when there is a match on any bit position of the access codes on Electronic-Key and DIP switch.

Example for access to operating state 0

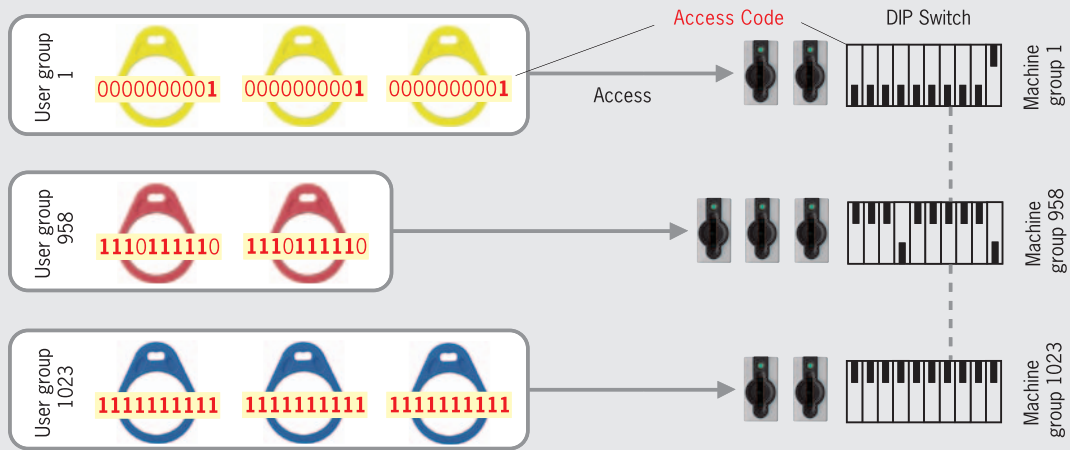

Example for access to operating state 1

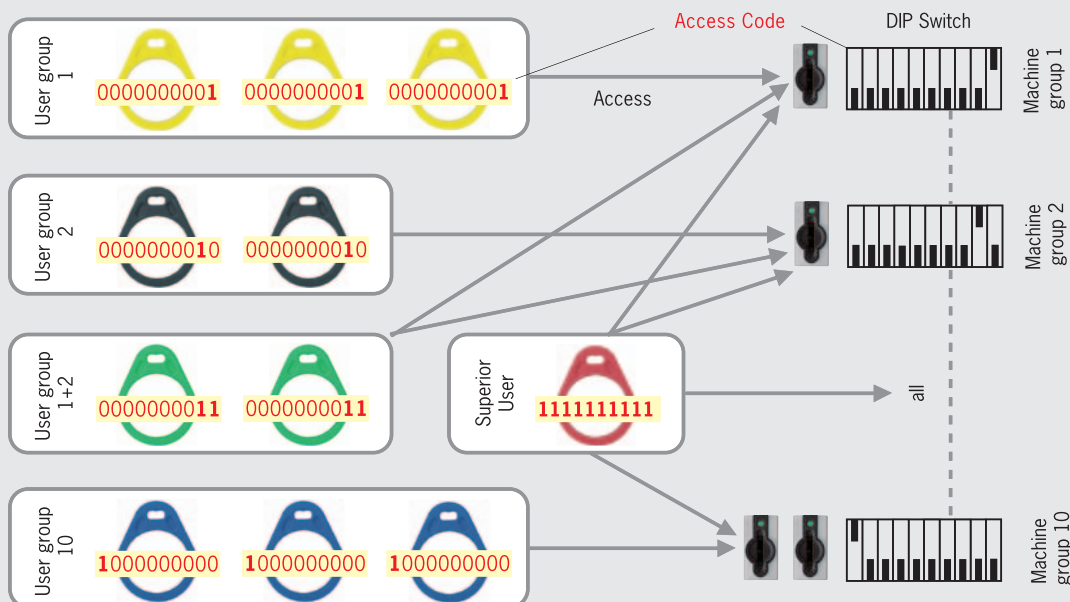

Electronic-Key-Manager – EKM *Light*

How are parameters assigned to Electronic-Keys?

Parameter assignment for the Electronic-Keys is performed exclusively via a programming station on the PC. At least the following items are required for this purpose:

- A commercially available Windows PC
- An EKS Electronic-Key adapter with USB interface
- The Electronic-Key Manager EKM *Light* software

Programming takes place via the Electronic-Key-Manager EKM software with an EKS *Light* input mask suitable for the operating state:

The EKM *Light* Version is sufficient at first. It can be upgraded to an EKM single-user or full version later. With this upgrade there is always a good overview about the database and all the already entered Electronic Keys.

The cyclic redundancy check routine prevents data manipulation outside of the defined software environment.



Ordering table			
Designation	Color	Item	Order no.
Electronic-Key adapter EKS <i>Light</i> compact (supports only operating state 0)	Grey/Black	EKS-A-IPB-G01-ST05/02	111 230
Electronic-Key adapter EKS <i>Light</i> compact (supports all operating states)	Grey/Black	EKS-A-IPL-G01-ST05/02	109 820
Electronic-Key adapter EKS <i>Light</i> FSA compact (supports all operating states)	Grey/Black	EKS-A-IPLA-G01-ST05/04	112 207
Electronic-Key adapter EKS Front hook modular FHM with 2 m connection cable*	Dark grey	EKS-A-SFH-G30-2000	106 585
Interface adapter EKS <i>Light</i> modular (supports only operating state 0)*		EKS-A-APB-G08	113 665
Interface adapter EKS <i>Light</i> modular (supports all operating states)*		EKS-A-APR-G08	113 647
Interface adapter EKS <i>Light</i> FSA modular (supports all operating states)*		EKS-A-APRA-G08	113 645
Electronic-Key read/write**	Red	EKS-A-K1RDWT32-EU	077 859
	Black	EKS-A-K1BKWT32-EU	084 735
	Blue	EKS-A-K1BUWT32-EU	091 045
	Green	EKS-A-K1GNWT32-EU	094 839
	Yellow	EKS-A-K1YEWT32-EU	094 840
For setup of a programming station			
Electronic-Key adapter with USB interface**		EKS-A-IUX-G01-ST01	092 750
Electronic-Key-Manager EKM** software, <i>Light Version</i> , on CD			111 410
Documentation			
Electronic-Key adapter manual; PDF file available in the <i>Download area at www.euchner.de</i>			110 845

* A complete read station consists of the Electronic-Key adapter and an interface adapter

** Detailed information about the standard EKS software and hardware components in the EKS catalog

Dimension drawing

Electronic-Key adapter EKS *Light compact*

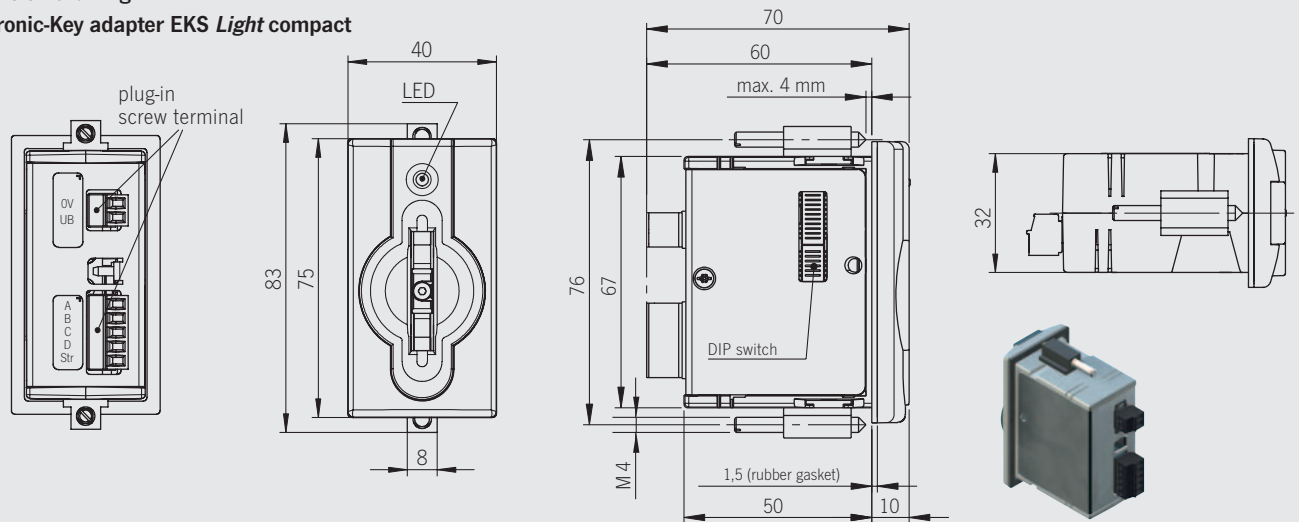

Dimension drawing

Electronic-Key adapter EKS *Light FSA compact*

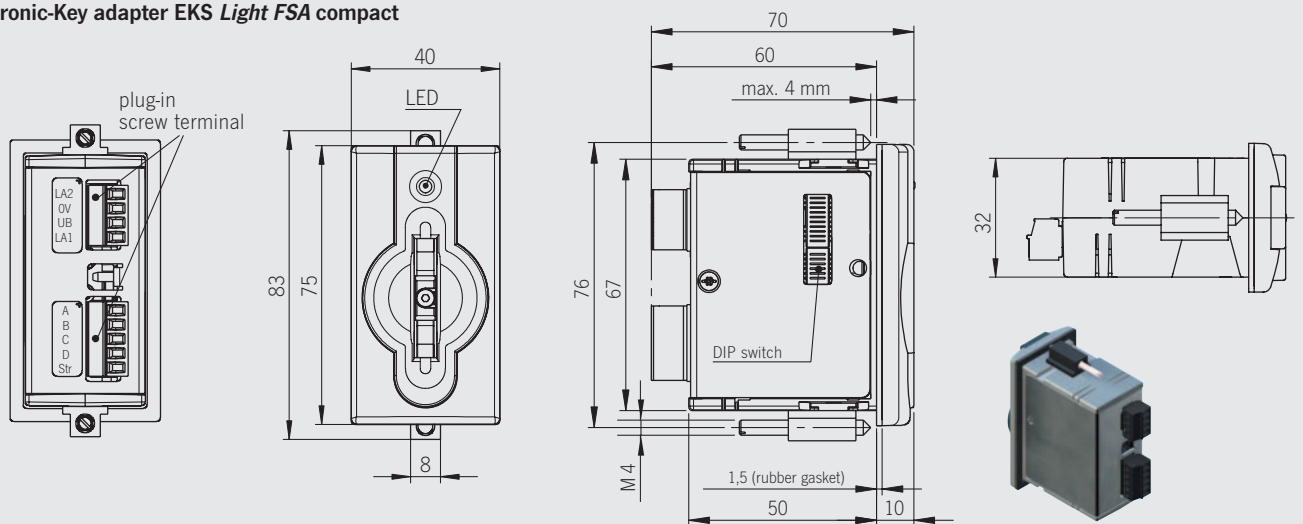

Dimension drawing

**Interface adapter EKS *Light modular*
Interface adapter EKS *Light FSA modular***

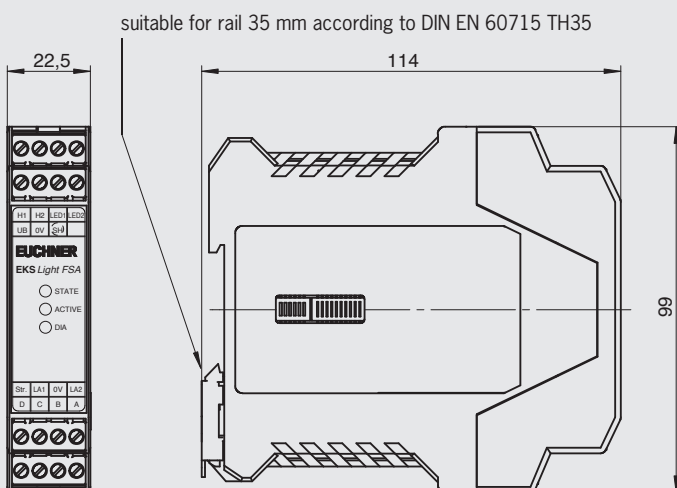

Dimension drawing

Electronic-Key adapter EKS *Front hook modular FHM*

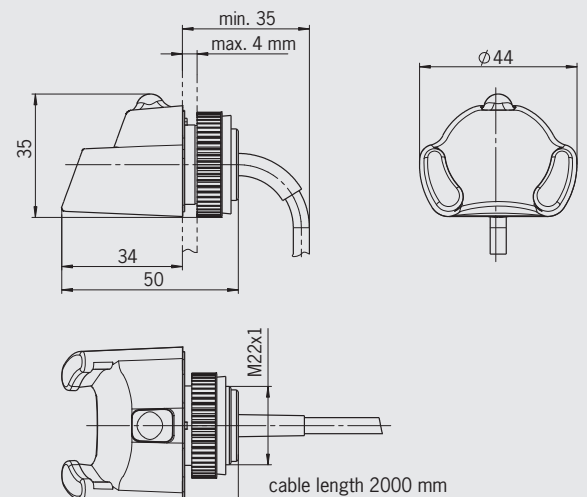

I FSA Version (For Safety Applications)

The Electronic-Key adapter EKS *Light* is alternatively available in the *FSA (For Safety Applications)* version. To solve the widespread problem of tampering with safety guards, EKS *Light* has been expanded for safety-related applications in conjunction with operating mode selection. The access rights are assigned via EKS in the first step and the desired operating mode is selected via another device in the second step. Trained personnel are thereby specifically authorized to perform critical setup and maintenance work in a special, hazardous operating mode.

The *FSA* version features an additional floating switched semiconductor switching contact that can be utilized to form a safe shut-down signal. For this purpose a safe evaluation must be connected downstream. The EKS *Light FSA* can thereby be used for safety-relevant applications. The machine is reset to a safe operating mode by removing the Electronic-Key.



Functionality of *FSA* version

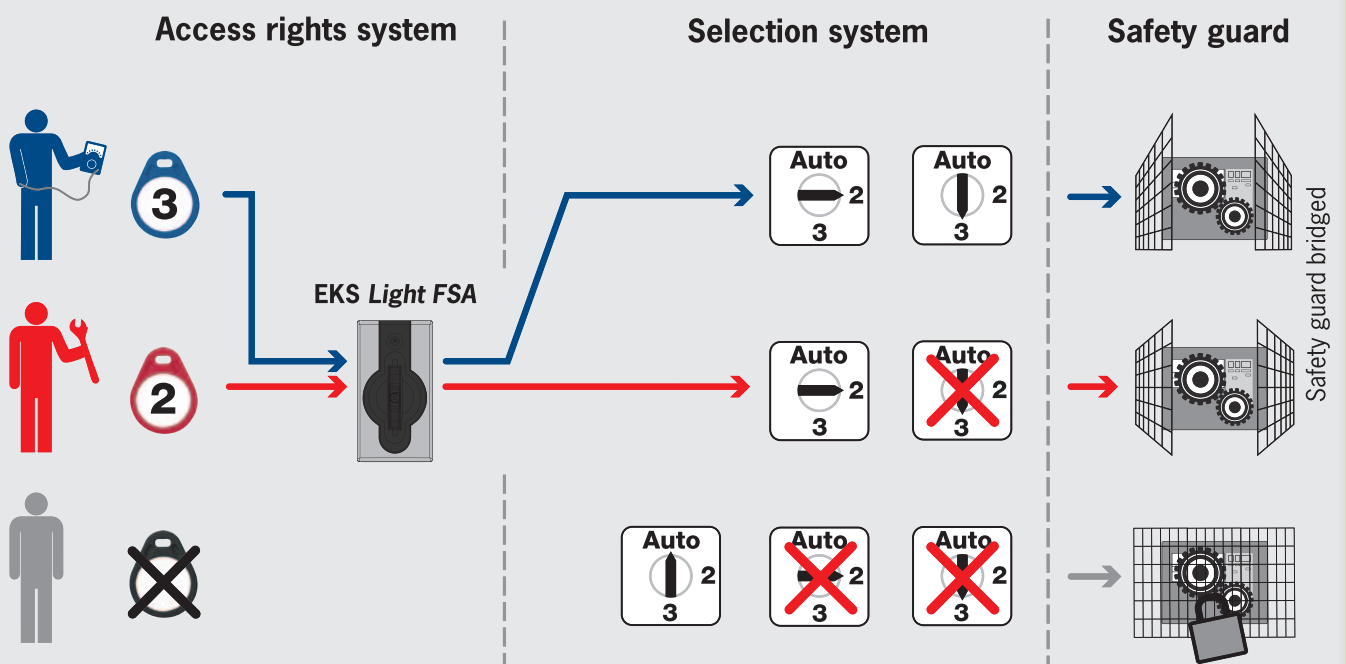

Technical data

	Value			Unit
	min.	typ.	max.	
General parameters Electronic-Key adapter compact				
Housing	Plastic (PA 6 GF30 grey/black)			
Degree of protection according to EN 60529	IP 65, IP 67 in mounted condition			
Ambient temperature at $U_B = 24$ V DC	-20		+70	°C
Mounting cut-out according to DIN 43700	33 x 68			mm
Connection type for power supply, outputs and semiconductor switching contact	2 plug-in screw terminals 2- and 5-pole 2 plug-in screw terminals 4- and 5-pole (FSA version) Conductor cross-section 0.14 ... 1.5 mm ² , tightening torque 0.22 Nm			
General parameters Electronic-Key adapter Front hook modular FHM				
Housing	Plastic (PVDF GF30 grey)			
Degree of protection according to EN 60529	IP 65, IP 67 (IP 69K in test) in mounted condition			
Ambient temperature at $U_B = 24$ V DC	-20		+70 (+120 in test)	°C
Mounting hole	Ø22,5			mm
Connection	Cable permanently connected to Electronic-Key adapter, with flying lead			
Cable length	2			m
Connection cable cross-section	4 x 0,25 screened			mm ²
Connection cable outer sheath	PVC			
General parameters interface adapter modular				
Housing	Plastic (PA 6.6)			
Ambient temperature at $U_B = DC 24$ V	0 (-20 in test)		+55 (+70 in test)	°C
Mounting	35-mm DIN rail acc. to DIN EN 60715 TH35			
Connection type power supply, outputs, Electronic-Key adapter and semiconductor switching contact (FSA)	Four plug-in screw terminals, 4-pole, Conductor cross-section 0.14 ... 2.5 mm ²			
Cable length to Electronic-Key adapter		2	15	m
Electronics, interface and signaling				
Operating voltage U_B (regulated, residual ripple < 5 %)	9	24	28	DC V
Current consumption I_B (without load current)			70	mA
Interface to inputs of control system or switch unit	4-bit parallel plus strobe, binary coded via High/Low level			
Load current per output I_A	1	10	50	mA
Output voltage U_A (High level) for A,B,C,D, Strobe	$U_B - 2$		U_B	V
Cable length to control system			50	m
LED-indicator	Green: »Ready« (in operation) Yellow: »Electronic-Key active« Red: »Error«			
FSA version (For Safety Applications) - parameters for floating semiconductor switching contact LA				
Power supply for load U (LA)		24	30	V
Switching current (with overload protection*)	1	10	50	mA
Output voltage High for U (LA)	$U \times 0,9$		U	
Resistance in switched-on state		35		Ohm
Capacitive load			1	µF
Utilization category according to EN 60947-5-2	AC-12 AC-15 DC-12 DC-13	50 mA / 24 V		
Reliability values according to EN ISO 13849-1 (only FSA version)				
Category (with connected safe evaluation)	3			
MTTFd	200			Years
DC	92			%

* Function description of the overload protection in the Electronic-Key adapter manual, order No. 110 845

More than safety.

EUCHNER GmbH + Co. KG
Kohlhammerstraße 16
70771 Leinfelden-Echterdingen
Germany

Tel. +49-(0)711-7597-0
Fax +49-(0)711-753316
info@euchner.de
www.euchner.com



EUCHNER